

# G-1200 25 HP Phase Drive

## Versatile benefits:

- Leader and originator of phase drives
- Quality with remarkable performance for over 40 years
- On-the-fly instantaneous adjustment
- Quick and easy installation
- Rugged, precision-built construction
- Versatile with a wide range of applications
- Popular models in stock
- Various mounting styles and shaft positions
- Value-added customer modifications
- 1 year warranty

The A. Fischer Phase-Drive offers a reliable, simple and precise unit that solves problems of phase adjustment, registration and timing quickly and efficiently. In addition, it also has the added inherent ability to be used as a speed reducer in 4:1 or 2:1 ratio.

Adjusting the timing of various power transmission components often requires costly disassembly and re-positioning of shafts, gears, or chains, to bring about the proper phase position of one shaft with another.

### HOW IT WORKS

Adjustment shaft, through worm-and-gear arrangement, rotates ring gear engaging three planetary gears in a housing connected to the output shaft and spiral bevel gear set, thereby advancing or retarding the output shaft position in relation to the input shaft.

### EASY TO INSTALL

You can cut into any existing line shaft, couple the driving and driven shafts at either end, and you have instant adjustment of the rotational positions of the input and output shafts in relationship to each other.

The unit can be used with a great variety of position sensing equipment, such as holding registration on printed stock during automatic cut-off operations. Typical applications include conveyor drives, printing rollers, dispensers, textile machinery, food processing, indexing heads, paper converting, feeders, cut-off machines, plastic web or film machinery, level winding machinery, packaging machines, speed correction, etc.

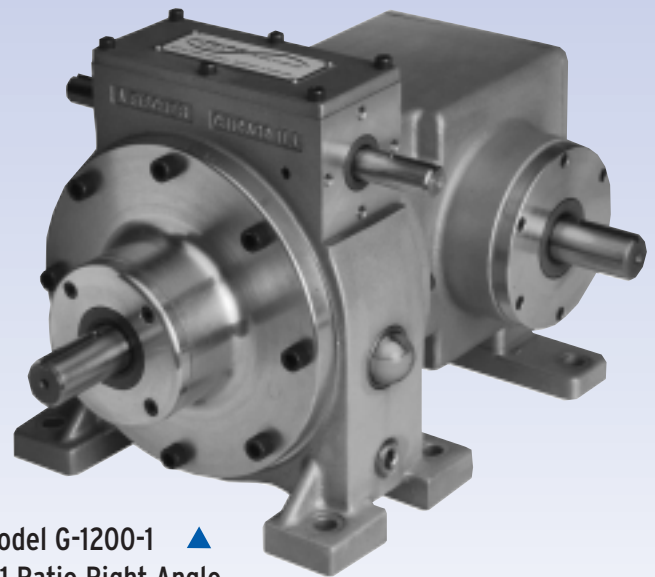

Model G-1200-1 ▲  
2:1 Ratio Right Angle  
Model G-1200-2  
4:1 Ratio Right Angle  
Model G-1200-3  
4:1 Ratio Right Angle

### MANUAL OR ELECTRIC OPERATION

Unlimited instantaneous adjustments in the input - output shaft relationships, through the entire 360°, are made simply by turning the adjustment shaft at the top of the unit. This may be done while running or stopped, manually by means of an available optional handwheel or connected at some distance by flexible shaft or universal joint arrangement. For automatic or remote operation, several motor packages are available.

Input and output shafts revolve in either direction; both turn the same way and are the same diameter. The unit also functions as a 4:1 or 2:1 speed reducer.

### PRECISION BUILT, FIELD TESTED

A. Fischer Phase Drives are precision engineered and quality built throughout. All components are machined to exacting tolerances, utilizing CNC machining and turning centers to assure minimal variation and consistent interchangeability. A. Fischer Phase Drives include superior component parts like high quality taper roller bearings, precision needle bearings, hardened and tooth-form ground gearing.

The quality and durability of A. Fischer Phase Drives has been proven in the field during the past 40 years. Many drives have been in constant operation, up to 24 hours a day/7 days a week with minimum attention through their operating life. We have designed and built A. Fischer Phase Drives so that they will surpass your engineering requirements and provide you with long lasting and dependable service.

# G-1200 Phase Drives

## Long-Lasting Engineering Features

**Lubrication:** AGMA #4EP/ISO 150 gear oil is used in a positive splash system, integral sump, with an oil level sight glass for easy observation. Each Phase Drive is supplied with a breather vent and magnetic oil drain plug.

**Shafts:** Input and output shafts hardened and ground. Ground locknut threads.

**Bearings:** Input and output shafts have quality taper roller bearings. Planetary gears run on precision needle bearings. Adjustment shaft bearings of oil impregnated bronze. All shafts protected by oil seals.

**Housing:** #A356-T6 high strength and close grained impregnated aluminum alloy castings.

**Gears:** Hardened and precision ground on tooth form. Spiral bevel gears are a matched precision lapped set.

**Gear Cage:** Ductile iron and alloy steel.

**H.P. Ratings:** Series 25 H.P.

Model G-1200-1 Weight: 80 lbs. 2:1 Ratio					
INPUT		OUTPUT			
H.P.	R.P.M.	R.P.M.	Torque In-lb.	Maximum Overhung Load LB.	Maximum Thrust (In or Out) LB.
42.3	3600	1800	1481	421	158
41.2	3450	1725	1505	426	161
37.3	3000	1500	1567	445	168
32.0	2400	1200	1681	476	179
26.0	1800	900	1821	519	196
25.0	1725	863	1827	525	198
19.8	1200	600	2080	561	211
19.0	1140	570	2101	595	224
17.3	1000	500	2181	618	233
14.3	750	375	2403	675	254
10.6	500	250	2672	762	286
6.7	250	125	3378	940	354
3.5	100	50	4412	1233	465

Model G-1200-2 4:1 Ratio					
INPUT		OUTPUT			
H.P.	R.P.M.	R.P.M.	Torque In-lb.	Maximum Overhung Load LB.	Maximum Thrust (In or Out) LB.
42.3	3600	900	2962	594	195
41.2	3450	863	3009	601	198
37.3	3000	750	3134	628	207
32.0	2400	600	3361	672	222
26.0	1800	450	3641	732	242
25.0	1725	431	3656	742	244
19.8	1200	300	4160	792	260
19.0	1140	285	4202	840	277
17.3	1000	250	4361	872	287
14.3	750	188	4794	953	314
10.6	500	125	5345	1075	354
6.7	250	63	6703	1327	436
3.5	100	25	8824	1741	574

Model G-1200-3 4:1 Ratio					
INPUT		OUTPUT			
H.P.	R.P.M.	R.P.M.	Torque In-lb.	Maximum Overhung Load LB.	Maximum Thrust (In or Out) LB.
42.3	3600	900	2962	495	186
41.2	3450	863	3009	501	189
37.3	3000	750	3134	523	197
32.0	2400	600	3361	560	211
26.0	1800	450	3641	610	230
25.0	1725	431	3656	618	233
19.8	1200	300	4160	660	248
19.0	1140	285	4202	700	164
17.3	1000	250	4361	727	274
14.3	750	188	4794	794	299
10.6	500	125	5345	896	337
6.7	250	63	6703	1106	416
3.5	100	25	8824	1451	547

Horizontal, vertical (wall mount), or inverted mounting styles available.

## Optional Handwheel Available

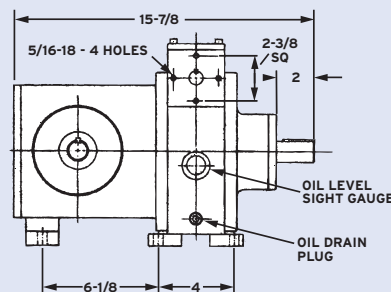
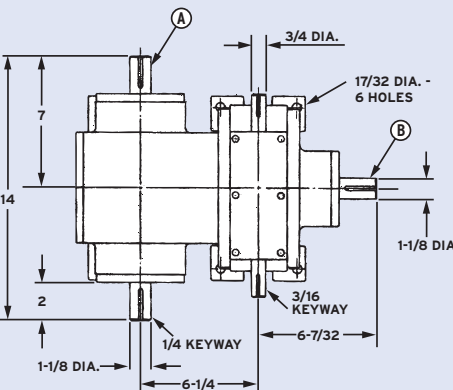

Model #	Input Shaft	Output Shaft	Ratio
G-1200-1	A	B	2:1
G-1200-2	B	A	4:1
G-1200-3	A	B	4:1

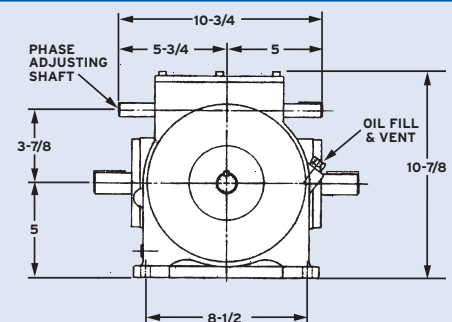

One Rotation of Adjustment Shaft, while running or stopped, provides approximately 5 1/2° Radial Movement of Output Shaft (66:66:1 Ratio)