

# G-1300 25 HP Phase Drive

## Versatile benefits:

- Leader and originator of phase drives
- Quality with remarkable performance for over 40 years
- On-the-fly instantaneous adjustment
- Quick and easy installation
- Rugged, precision-built construction
- Versatile with a wide range of applications
- Popular models in stock
- Various mounting styles and shaft positions
- Value-added customer modifications
- 1 year warranty

The A. Fischer Phase-Drive offers a reliable, simple and precise unit that solves problems of phase adjustment, registration and timing quickly and efficiently. In addition, it also has the added inherent ability to be used as a speed reducer in 4:1 ratio.

Adjusting the timing of various power transmission components often requires costly disassembly and re-positioning of shafts, gears, or chains, to bring about the proper phase position of one shaft with another.

### HOW IT WORKS

Adjustment shaft, through worm-and-gear arrangement, rotates ring gear engaging three planetary gears in a housing connected to the output shaft, thereby advancing or retarding the output shaft position in relation to the input shaft.

### EASY TO INSTALL

You can cut into any existing line shaft, couple the driving and driven shafts at either end, and you have instant adjustment of the rotational positions of the input and output shafts in relationship to each other.

The unit can be used with a great variety of position sensing equipment, such as holding registration on printed stock during automatic cut-off operations. Typical applications include conveyor drives, printing rollers, dispensers, textile machinery, food processing, indexing heads, paper converting, feeders, cut-off machines, plastic web or film machinery, level winding machinery, packaging machines, speed correction, etc.

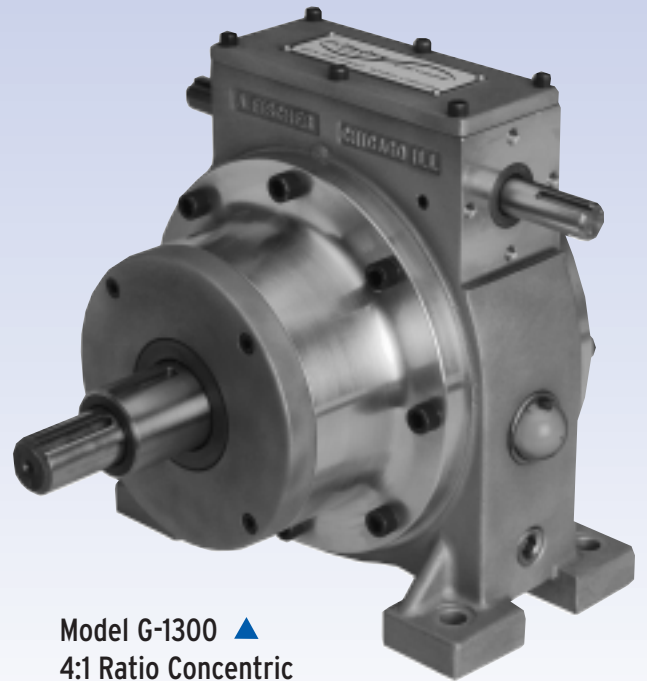

Model G-1300 ▲  
4:1 Ratio Concentric  
Input & Output

### MANUAL OR ELECTRIC OPERATION

Unlimited instantaneous adjustments in the input - output shaft relationships, through the entire 360°, are made simply by turning the adjustment shaft at the top of the unit. This may be done while running or stopped, manually by means of an available optional handwheel or connected at some distance by flexible shaft or universal joint arrangement. For automatic or remote operation, several motor packages are available.

Input and output shafts revolve in either direction; both turn the same way and are the same diameter. The unit also functions as a 4:1 speed reducer.

### PRECISION BUILT, FIELD TESTED

A. Fischer Phase Drives are precision engineered and quality built throughout. All components are machined to exacting tolerances, utilizing CNC machining and turning centers to assure minimal variation and consistent interchangeability. A. Fischer Phase Drives include superior component parts like high quality taper roller bearings, precision needle bearings, hardened and tooth-form ground gearing.

The quality and durability of A. Fischer Phase Drives has been proven in the field during the past 40 years. Many drives have been in constant operation, up to 24 hours a day/7 days a week with minimum attention through their operating life. We have designed and built A. Fischer Phase Drives so that they will surpass your engineering requirements and provide you with long lasting and dependable service.

# G-1300 Phase Drives

## Long-Lasting Engineering Features

**Lubrication:** AGMA #4EP/ISO 150 gear oil is used in a positive splash system, integral sump, with an oil level sight glass for easy observation. Each Phase Drive is supplied with a breather vent and magnetic oil drain plug.

**Shafts:** Input and output shafts hardened and ground. Ground locknut threads.

**Bearings:** Input and output shafts have quality taper roller bearings. Concentric input shaft runs on precision needle bearings. Planetary gears run on precision needle bearings. Adjustment shaft bearings of oil impregnated bronze. All shafts protected by oil seals.

**Housing:** #A356-T6 high strength and close grained impregnated aluminum alloy castings.

**Gears:** Hardened and precision ground on tooth form.

**Gear Cage:** Ductile iron and alloy steel.

**H.P. Ratings:** Series 25 H.P.

**Model G-1300 Weight: 56 lbs.  
4:1 Ratio**

INPUT		OUTPUT			
H.P.	R.P.M.	R.P.M.	Torque In-lb.	Maximum Overhung Load LB.	Maximum Thrust (In or Out) LB.
42.3	3600	900	2962	520	195
41.2	3450	863	3009	526	198
37.3	3000	750	3134	549	207
32.0	2400	600	3361	588	222
26.0	1800	450	3641	641	242
25.0	1725	431	3656	649	245
19.8	1200	300	4160	693	260
19.0	1140	285	4202	735	277
17.3	1000	250	4361	763	288
14.3	750	188	4794	834	314
10.6	500	125	5345	941	354
6.7	250	63	6703	1161	437
3.5	100	25	8824	1524	574

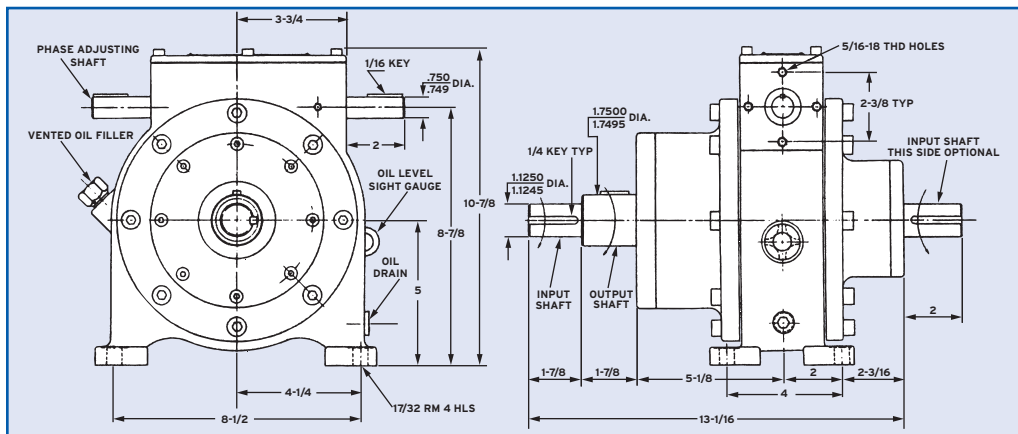

One Rotation of Adjustment Shaft, while running or stopped, provides approximately 5 1/2° Radial Movement of Output Shaft (66:66:1 Ratio)

## Mounting Styles & Shaft Positions (Optional Handwheel Available)

